

TECHNICAL SPECIFICATIONS

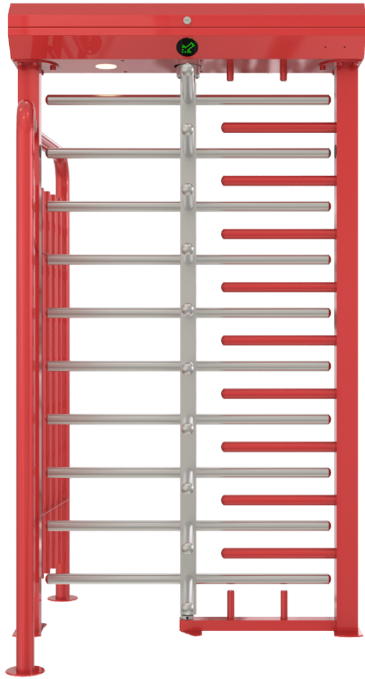

SINGLE UNIT

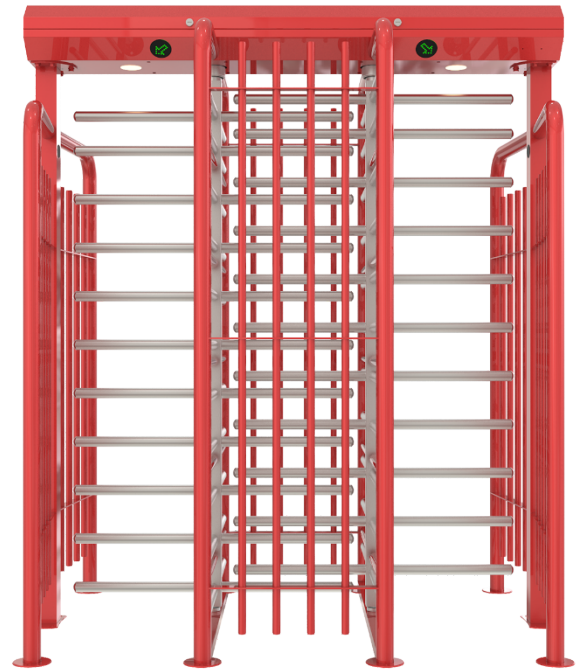

DOUBLE UNIT

GENERAL SPECIFICATIONS

Power	110/220 V – 60/50 Hz. AC (±% 10), 24 V DC. by switching mode power supply (SMPS) and filtered. Consumption: Stand-by ~8W , max. ~20W (single unit). Stand-by ~8W+8W, max. ~20W+20W (double unit).
Arms	Four-section (a pair for double-unit) rotors (90°). Each section contains ten (eleven for double-sided) Ø42mmx2.5mm electrostatic powder coated (opt. hot dipped galvanized) or Ø40mm 304-grade (opt. 316-grade) Stainless Steel (opt. Ø38, Ø42 and Ø45mm) arms.
Body Features	Constructed on main carriers, supported by tube and square profiles on lateral panels, strengthened by separators. Made of 304-grade (opt. 316-grade) brushed finished stainless steel, electrostatic painted surface or mixed combination versions (opt. hot dip galvanizing under coating for outdoor models). Complying to UK H&S regulations of max. 98 mm gap between upright profiles. Top lid is protected against water for outdoors installation. Top lid is equipped with damper for safety and service convenience. Optional intelligent illumination system provides energy saving feature (illuminates automatically in darkness/at night and optionally can run parallel with site illumination).

Design and specifications are subject to change without notice.

TECHNICAL SPECIFICATIONS

Dimensions	Single : 1292 x 1310 x 2335mm Double : 1982 x 1310 x 2335mm
Weight	Single : ~260 kg Double : ~515 kg
Operation Temperature, Humidity, IP Rating	(-20°C) – (+68°C) (opt:- 50°C with heater positive), RH 95% (±2%) non-condensing), IP 56 (opt. IP 66)
Standard Specifications	Complying to UK H&S regulations of max. 98 mm gap between upright bars. Top lid equipped with damper for safety and service convenience.

SYSTEM SPECIFICATIONS

Indicators	Green arrow & red cross LED indicators on the top lid.
Control System	Controlled by dry contact or grounding input. All inputs are opto-coupler protected.
Integration	Compatible with all access control systems that provide dry contact or grounding outputs. Optional RS232/RS485/TCP IP control module is available.
System / Operation Features	<p>Manually operated (optional motorized), bi-directional system with dip switch selectable operational modes including free or controlled access on both-sides, one side free exit and restricted access modes.</p> <p>The passage directions can be activated by a separate input signal.</p> <p>With the double input feature, the direction of passage for both directions can be operated via a single signal.</p> <p>Vibration resistant, microprocessor controlled industrial design that can be adapted to meet every user's demands.</p> <p>Optionally can be equipped with speaker and WAV intercom speaking unit feature.</p> <p>System contains special design and CE certified solenoid switch that do not heat up more than max. 10°C of environment temperature.</p>
Soft Stop	Provided with hydraulic shock absorber.
Time-out	6-12-18 seconds dipswitch selectable or infinite to be controlled manually.
Output Data	System provides dry contact passage feedback by relays separately for each direction. System provides busy signal during passage

FUNCTIONAL FEATURES

Passage	<p>System operates bi-directional (in-out).</p> <p>A- Manual push (standard): Upon receipt of signal from the access control unit, the lock is released and the arms are manually pushed forward 90 ° in the direction of the signal.</p> <p>B- Motorized (optional): Upon receipt of signal from the access control unit, the lock is released and the arms rotate automatically 90 ° in the direction of the signal after being pushed slightly.</p> <p>C- Free Pass (optional): In this mode, the arms are free and locks to prevent access in case of unauthorized attempt.</p>
Emergency Mode	The rotor spins freely to allow free passage (Fail Safe default). Fail lock option is available upon request.

Design and specifications are subject to change without notice.

TECHNICAL SPECIFICATIONS

Flow Rate

Single Unit:

Capacity of mechanism (manual) : Max. 60 pass/min. Nominal : ~18 pass/min.
Capacity of mechanism (motorized) : Max. 48 pass/min. Nominal : ~15 pass/min.

Double Unit:

Capacity of mechanism (manual) : Max. 60+60 pass/min. Nominal : ~18+18 pass/min.
Capacity of mechanism (motorized) : Max. 60+60 pass/min. Nominal : ~15+15 pass/min.
*Utilisation of different access control units can change the flow rate.

CERTIFICATION

Compliance

CE, RoHS, Complying to UK H&S regulations of max. 98 mm gap between upright bars.

OPTIONAL ACCESSORIES AND APPLICATIONS

Options

Remote control units (RF or with cable), interface unit for PC, RS485, RS232 and LAN, counter, audio-messaging system, base plate, coin slot/ intelligent coin system and coin box, card reader pole, seat limiter for stadium solutions, animated indicators, internal battery and charge unit, motor driven unit, heater positive unit, separators, canopy, card reader mounting bracket, adaptation to building illumination.

Turnstile illumination can be programmed for various principles with the intelligent illumination system.

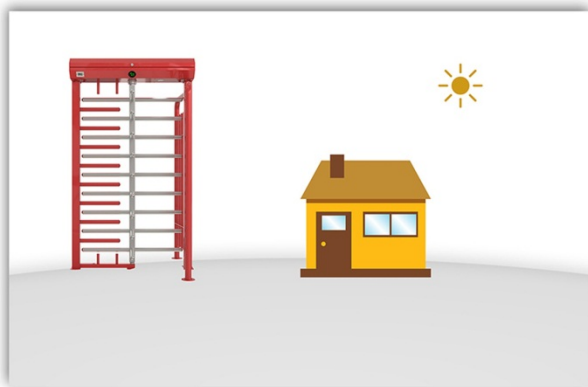

Illumination is disabled in day light.



Illumination is automatically enabled in darkness. Integration with the building/perimeter illumination is optionally available.

TECHNICAL SPECIFICATIONS

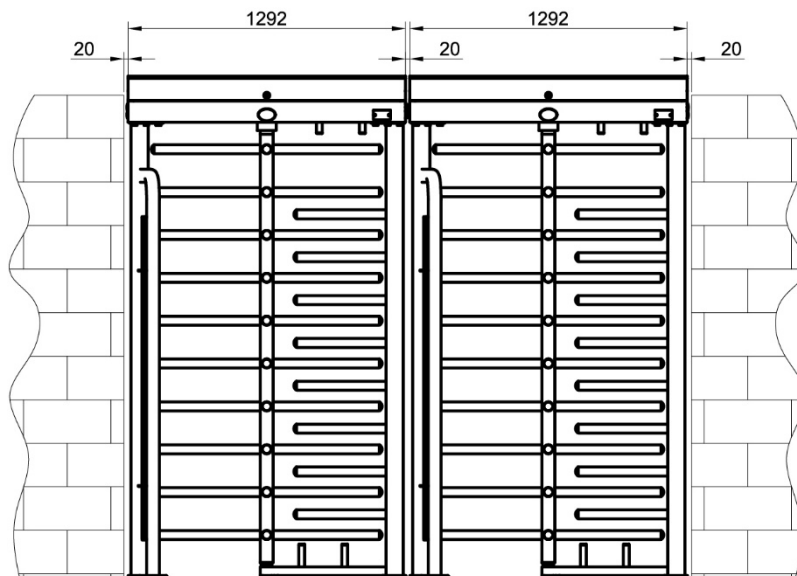
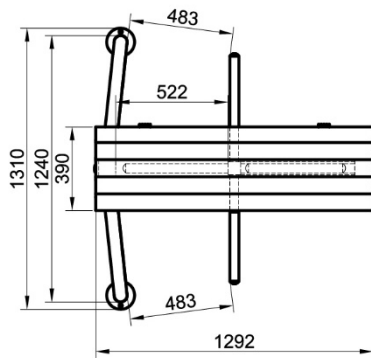
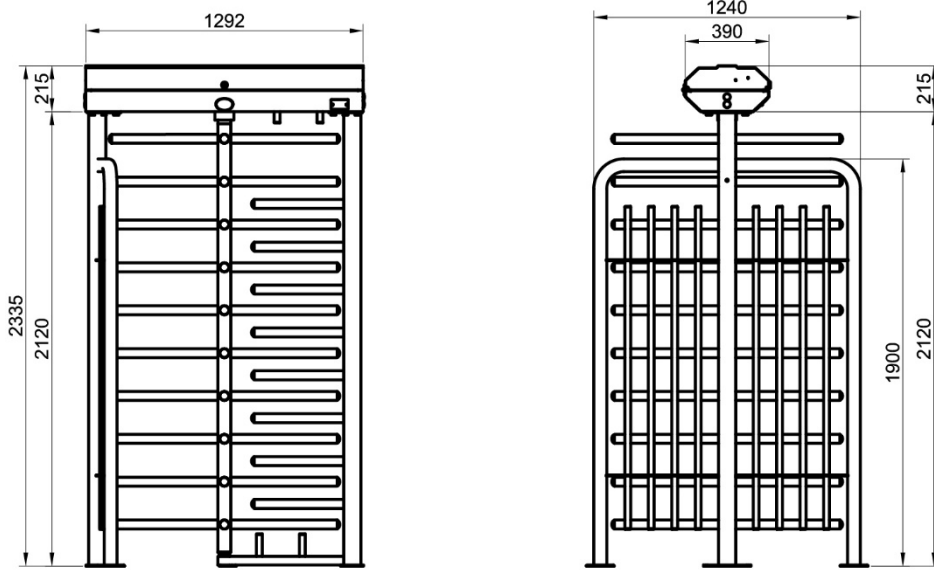

Design and specifications are subject to change without notice.

TECHNICAL SPECIFICATIONS

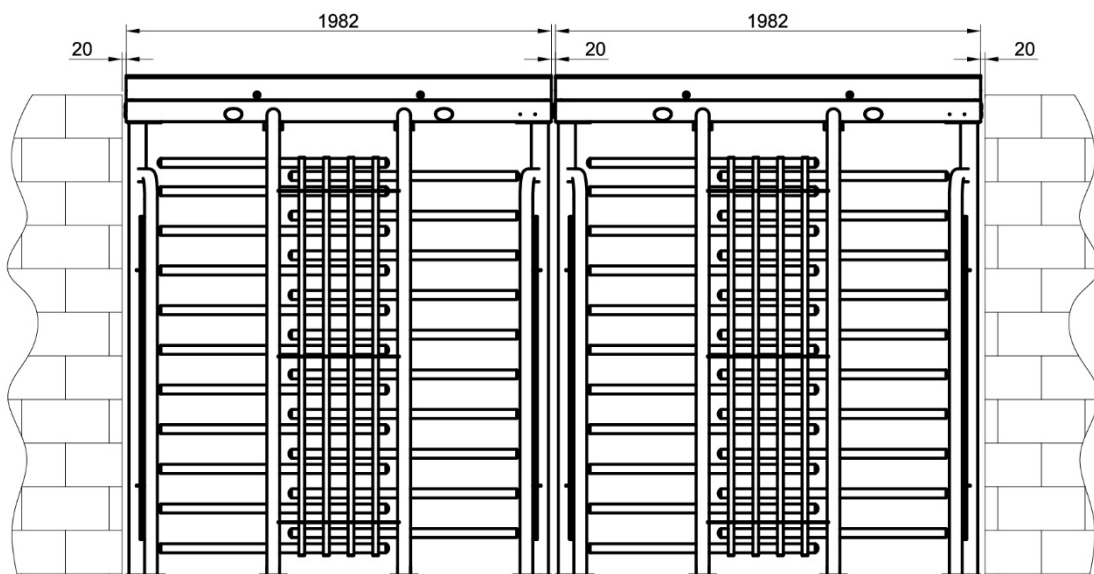
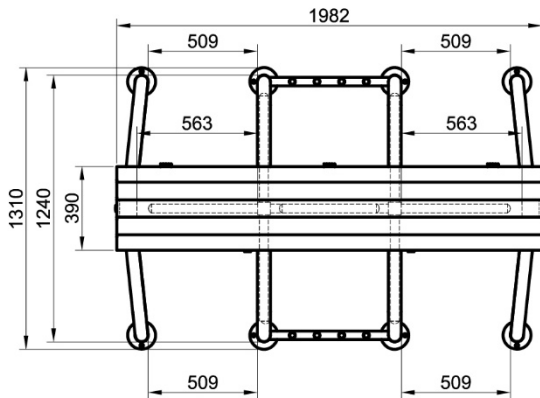
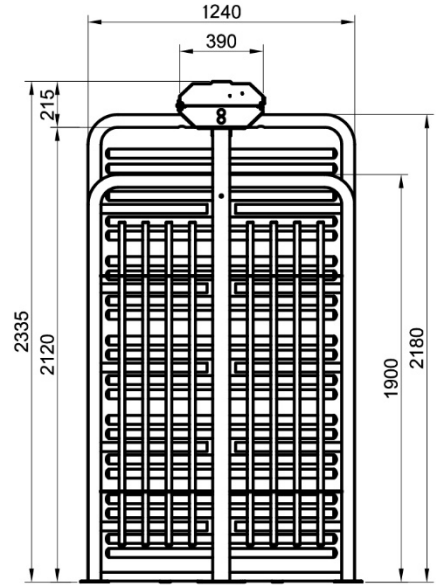
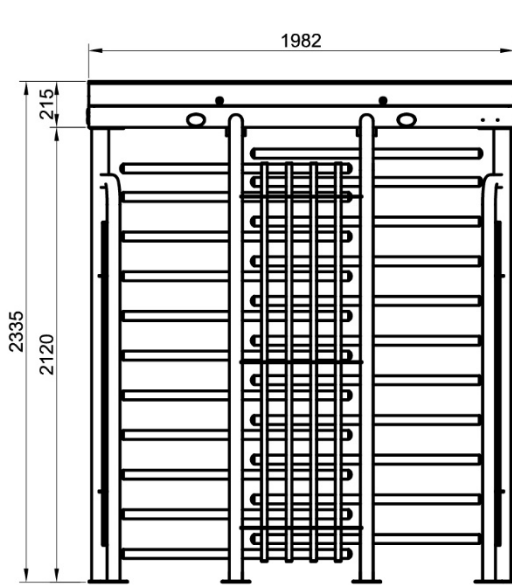

Design and specifications are subject to change without notice.